

12" Wide Vented Lockers – 72000 Series Double Tier Installation Instructions

Thank you for selecting Salsbury's 12" wide vented double tier lockers. These instructions are intended to assist you in assembling the lockers. Assembly of the various locker components will be with #10 - 24 x 3/8" long slotless screws and #10 nuts (provided). Loosely fasten a screw and a nut into every set of mating holes with the screw heads positioned on the outside of the locker or on the exposed surface.

One Wide Locker Assembly

Step 1: Attach the top shelf, bottom shelf, and two single coat hooks to the back panel.

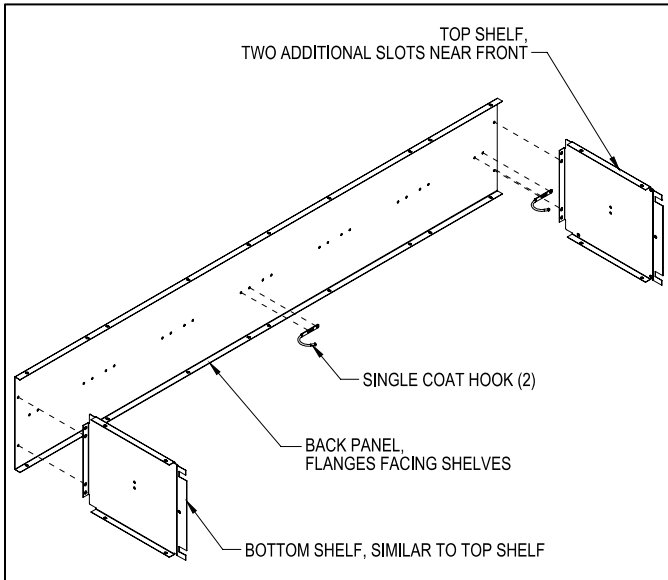

Step 2: Turn the back panel onto its back with the shelves pointing upward. Attach the first side panel, the left rear leg, and one compartment divider to the assembly from Step 1. Attach two additional single coat hooks to the first side panel, a double coat hook to the bottom of the top shelf, and a second double coat hook to the bottom of the compartment divider.

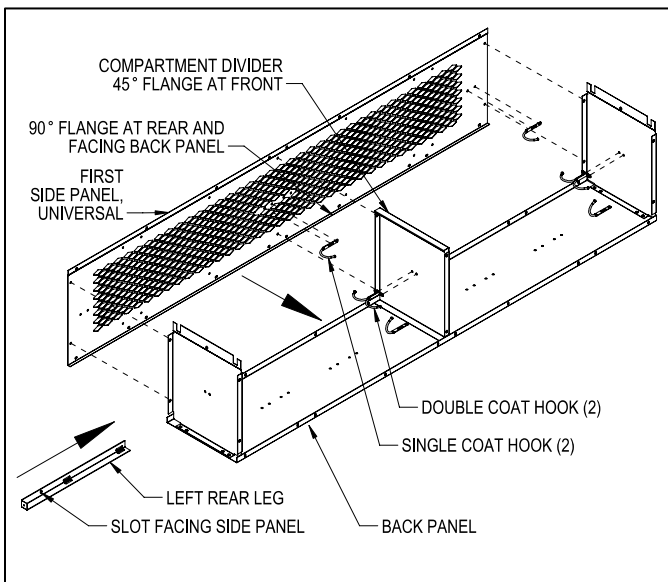

Step 3: Attach the second side panel and the right rear leg to the assembly from Step 2. Attach two additional single coat hooks to the second side panel. The locker chassis is now complete.

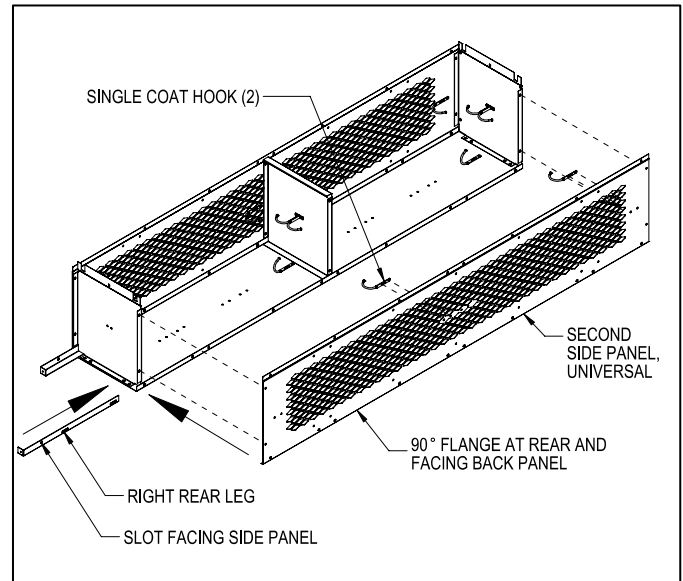

Step 4: Attach the pre-assembled door frame onto the assembly from Step 3.

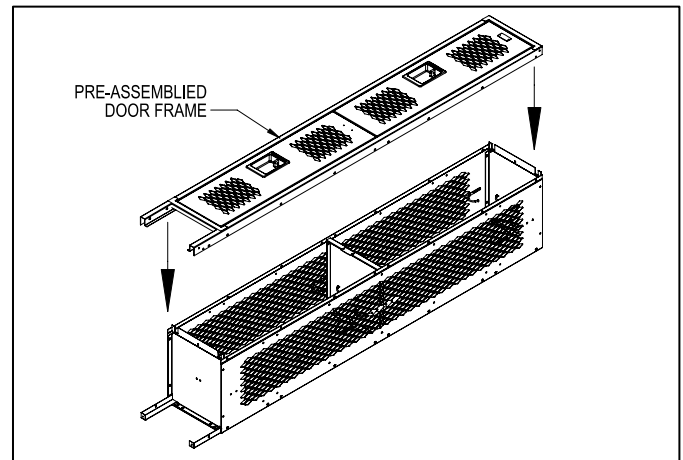

Step 5: Tighten all fasteners, ensuring the locker remains square during the process. If desired, attach optional sloping hood, end bases, or front base (see pages 4 and 5).

Step 6: Place the locker in the installation location and anchor to the floor, wall, or both. Individual job conditions will dictate the type of fastening anchors to use (not provided).

Step 7: Fasten all lockers in a row together by installing fasteners through the side panels. Installation is now complete.

SALSBUURY INDUSTRIES

18300 Central Avenue, Carson, CA 90746-4008
 Phone: 1-800-562-5377 Int'l Phone: 323-846-6700
 Fax: 1-800-562-5399 Int'l Fax: 323-846-6800
 www.lockers.com engineering@lockers.com

12" Wide Vented Lockers – 72000 Series Double Tier Installation Instructions

Three Wide Locker Assembly

Step 1: Attach a top shelf, a bottom shelf, and two single coat hooks to a back panel.

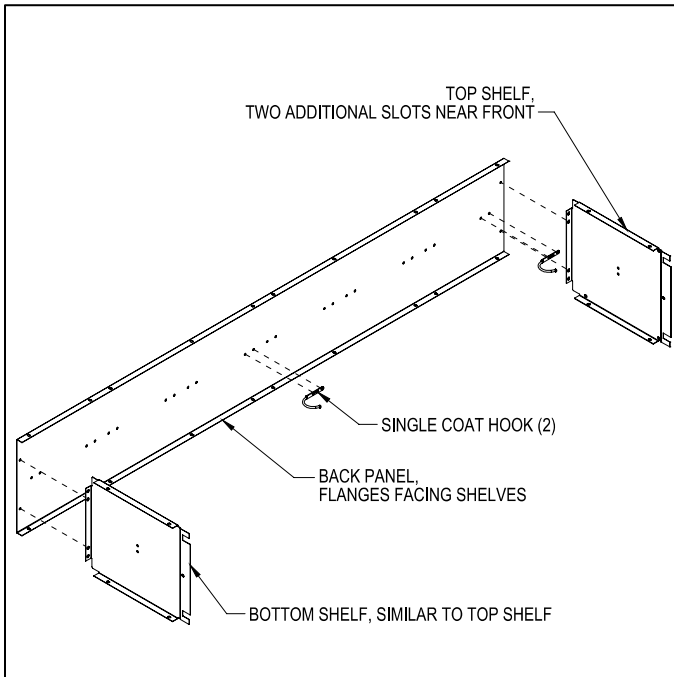

Step 2: Turn the back panel onto its back with the shelves pointing upward. Attach the first side panel, the left rear leg, and the first compartment divider to the assembly from Step 1. Attach two additional single coat hooks to the first side panel, one double coat hook to the bottom of the top shelf, and an additional double coat hook to the bottom of the compartment divider.

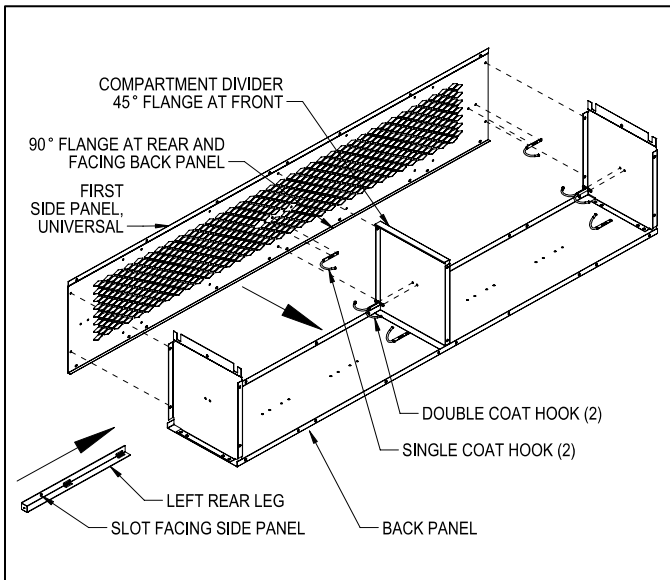

Step 3: Attach a second top shelf, a second bottom shelf, and two additional single coat hooks to a second back panel as in step 1.

Step 4: Simultaneously attach the assembly from Step 3, a second side panel, and a second compartment divider to the assembly from Step 2. Attach two single coat hooks to each side of the second side panel, one double coat hook to the bottom of the second top shelf, and an additional double coat hook to the bottom of the second compartment divider.

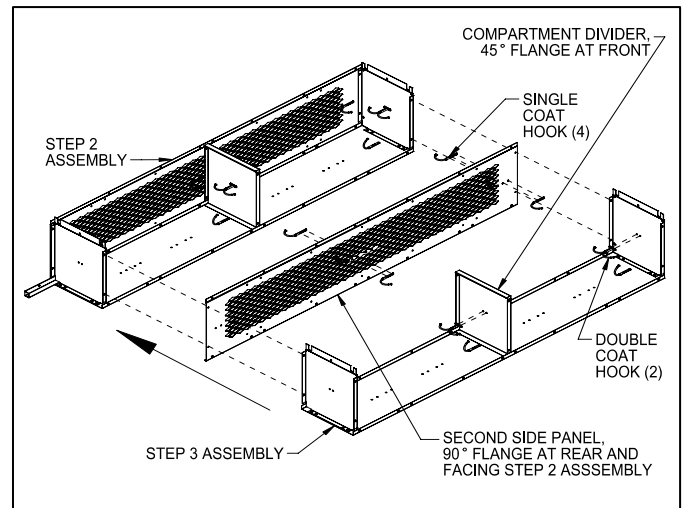

Step 5: Attach a third top shelf, a third bottom shelf, and two additional single coat hooks to a third back panel (as in Steps 1 and 3).

Step 6: Simultaneously attach the assembly from Step 5, a third side panel, and a third compartment divider to the assembly from Step 4. Attach two single coat hooks to each side of the second side panel, one double coat hook to the bottom of the second top shelf, and an additional double coat hook to the bottom of the second compartment divider.

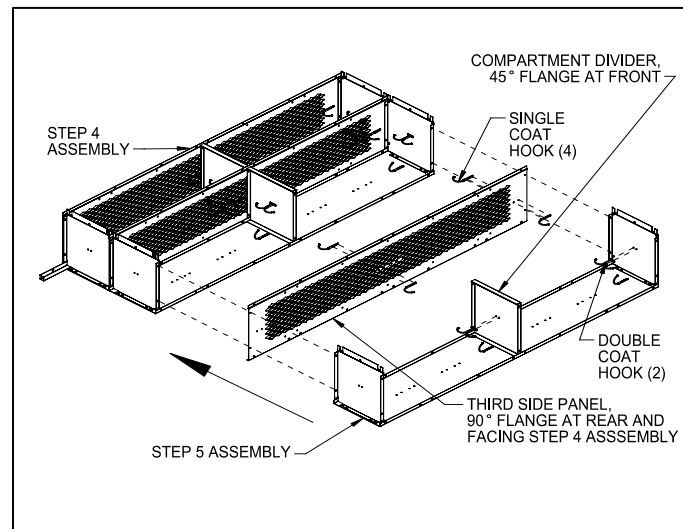

SALSBUURY INDUSTRIES

18300 Central Avenue, Carson, CA 90746-4008
 Phone: 1-800-562-5377 Int'l Phone: 323-846-6700
 Fax: 1-800-562-5399 Int'l Fax: 323-846-6800
 www.lockers.com engineering@lockers.com

12" Wide Vented Lockers – 72000 Series Double Tier Installation Instructions

Three Wide Locker Assembly (continued)

Step 7: Attach the last side panel and the right rear leg to the assembly from Step 6. Attach the last two single coat hooks to the last side panel. The locker chassis is now complete.

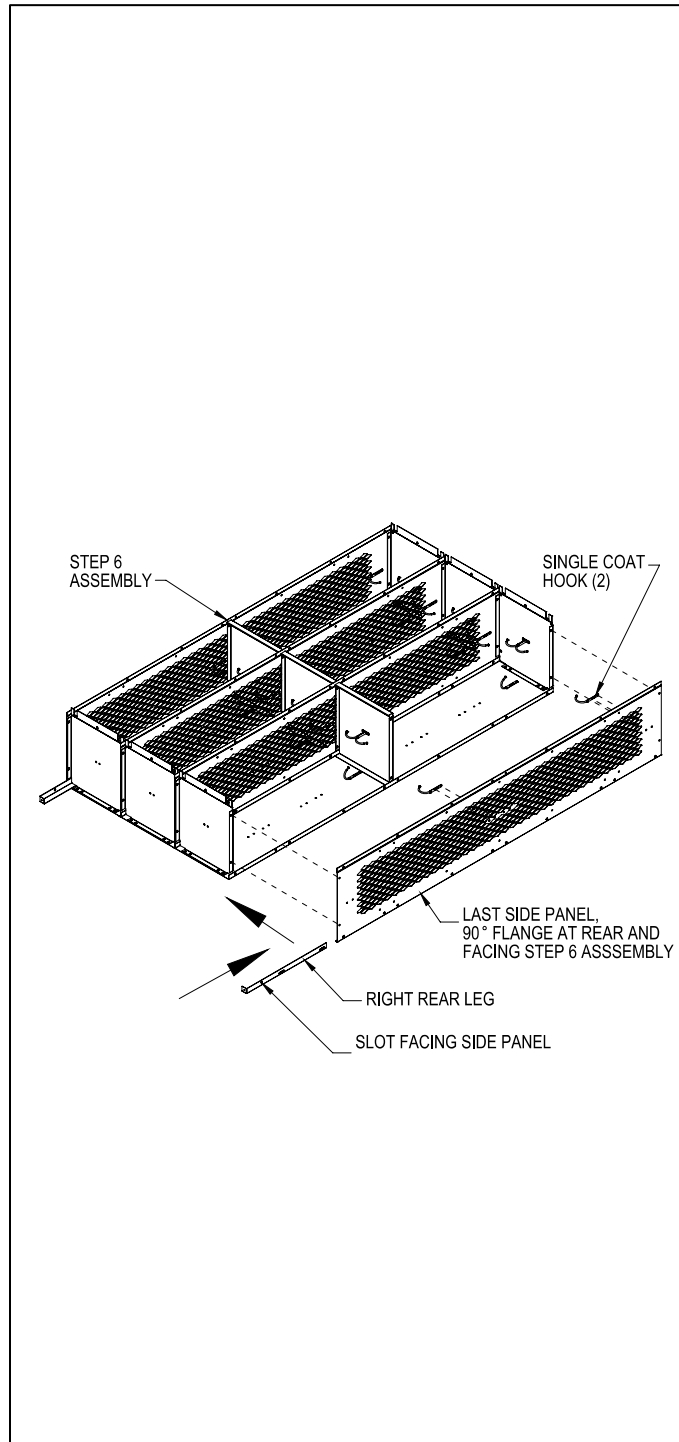

Step 8: Attach the pre-assembled door frames to the completed locker chassis from Step 7.

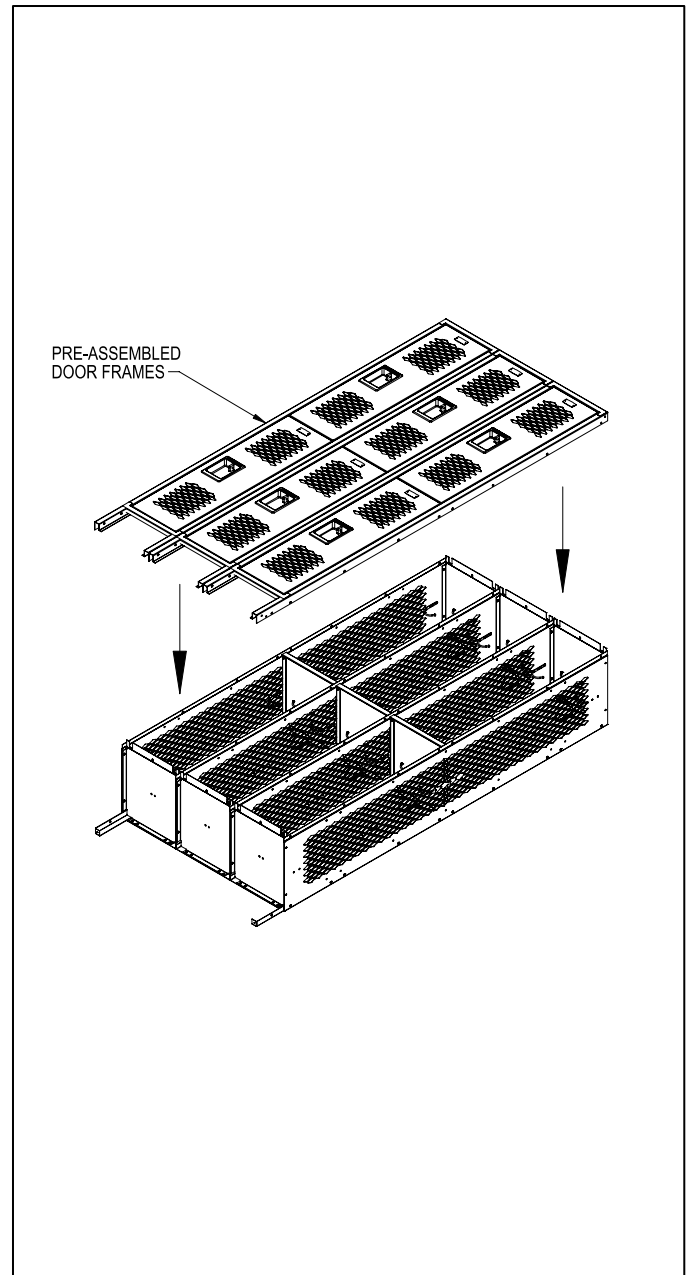

Step 9: Tighten all fasteners, ensuring the locker remains square during the process. If desired, attach optional sloping hood, end bases, or front base (see pages 4 and 5).

Step 10: Place the locker in the installation location and anchor to the floor, wall, or both. Individual job conditions will dictate the type of fastening anchors to use (not provided).

Step 11: Fasten all lockers in a row together by installing fasteners through the side panels. Installation is now complete.

SALSBURY INDUSTRIES

18300 Central Avenue, Carson, CA 90746-4008
Phone: 1-800-562-5377 Int'l Phone: 323-846-6700
Fax: 1-800-562-5399 Int'l Fax: 323-846-6800
www.lockers.com engineering@lockers.com

12" Wide Vented Lockers – 72000 Series Double Tier Installation Instructions

Sloping Hood Installation (Optional)

Step 1: Attach the top panel to the rear panel using #10-24 x 3/8" slotless screws and #10 nuts (provided). Position the flange of the top panel behind the rear panel.

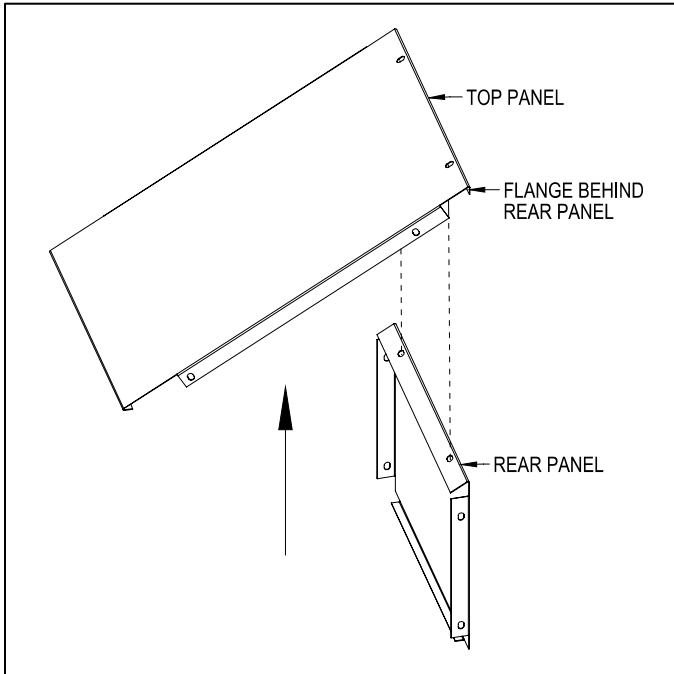

Step 2: Attach the side panels to the top panel and rear panel. Sloping hood assembly is now complete.

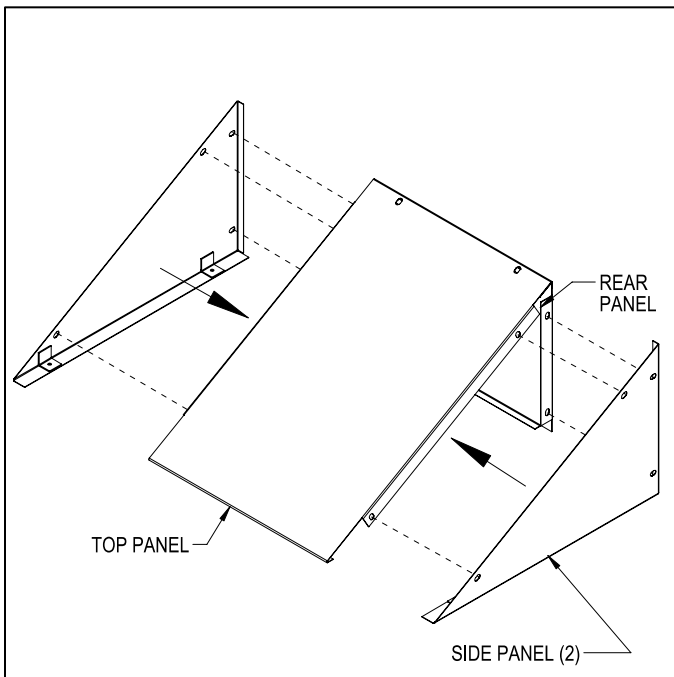

Step 3: Attach the sloping hood to the top of the locker with slotted #8 - 32 screws (provided).

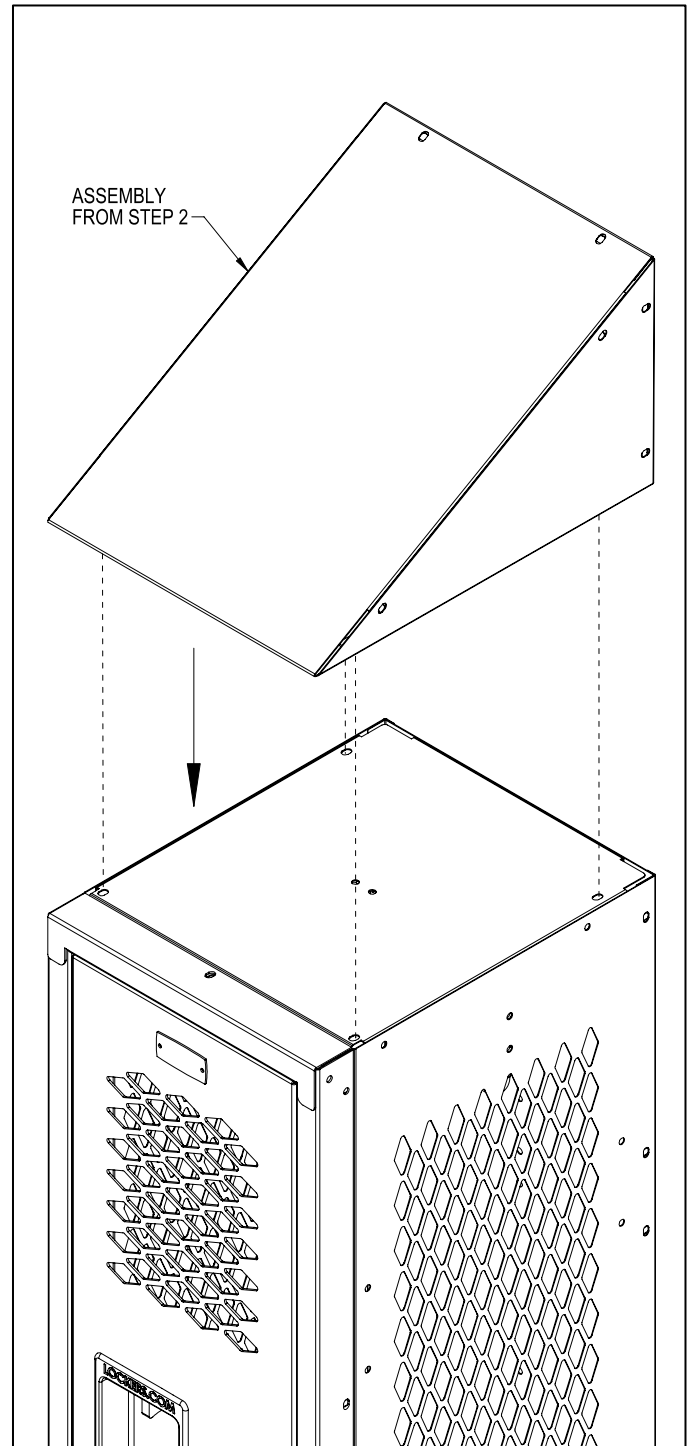

SALSBUURY INDUSTRIES

18300 Central Avenue, Carson, CA 90746-4008
Phone: 1-800-562-5377 Int'l Phone: 323-846-6700
Fax: 1-800-562-5399 Int'l Fax: 323-846-6800
www.lockers.com engineering@lockers.com

12" Wide Vented Lockers – 72000 Series Double Tier Installation Instructions

Front Base Installation (Optional)

Position the front base between the front legs of the locker with the flange upward. Attach to the locker legs with #10-24 x 3/8" slotless screws and #10 nuts (provided).

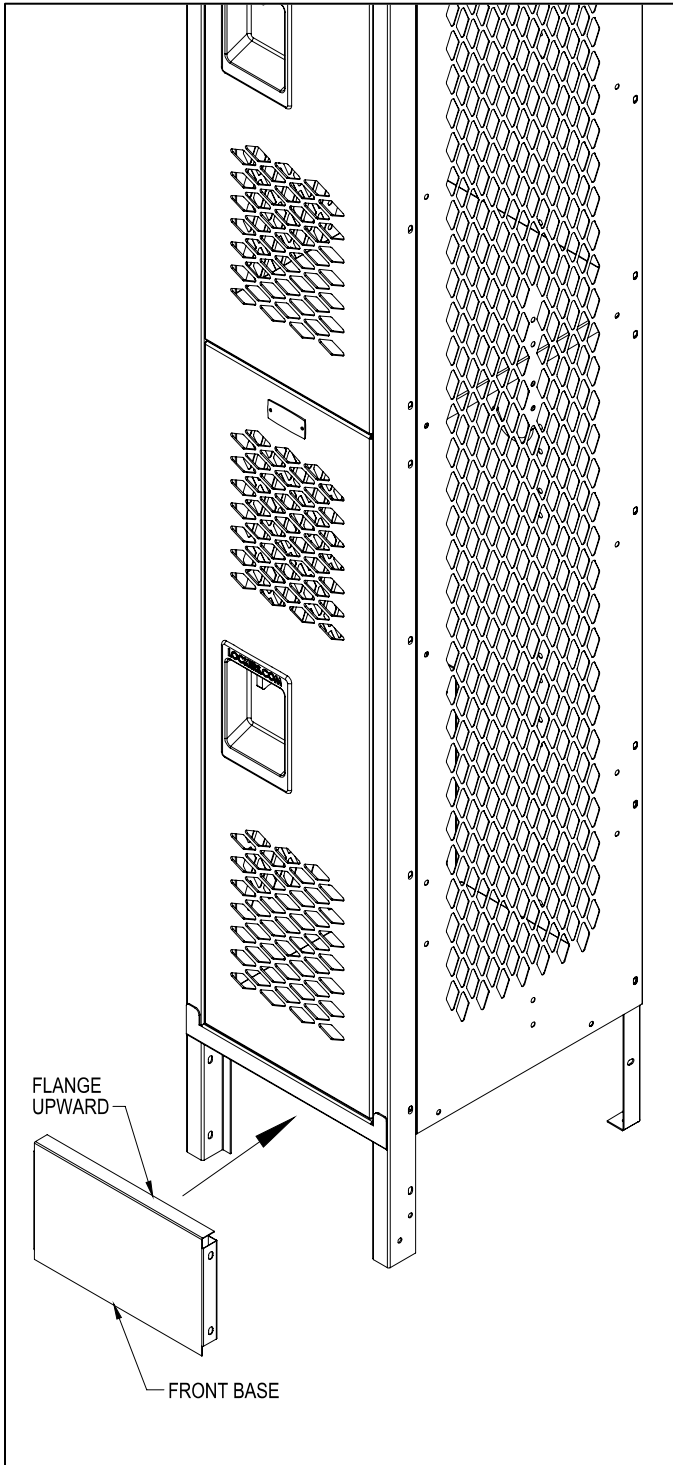

End Base Installation (Optional)

Position the appropriate end base (right or left) behind the corresponding side legs (right or left) of the locker with the flange upward. Attach to the locker legs with #10-24 x 3/8" slotless screws and #10 nuts (provided). Repeat for the opposite side.

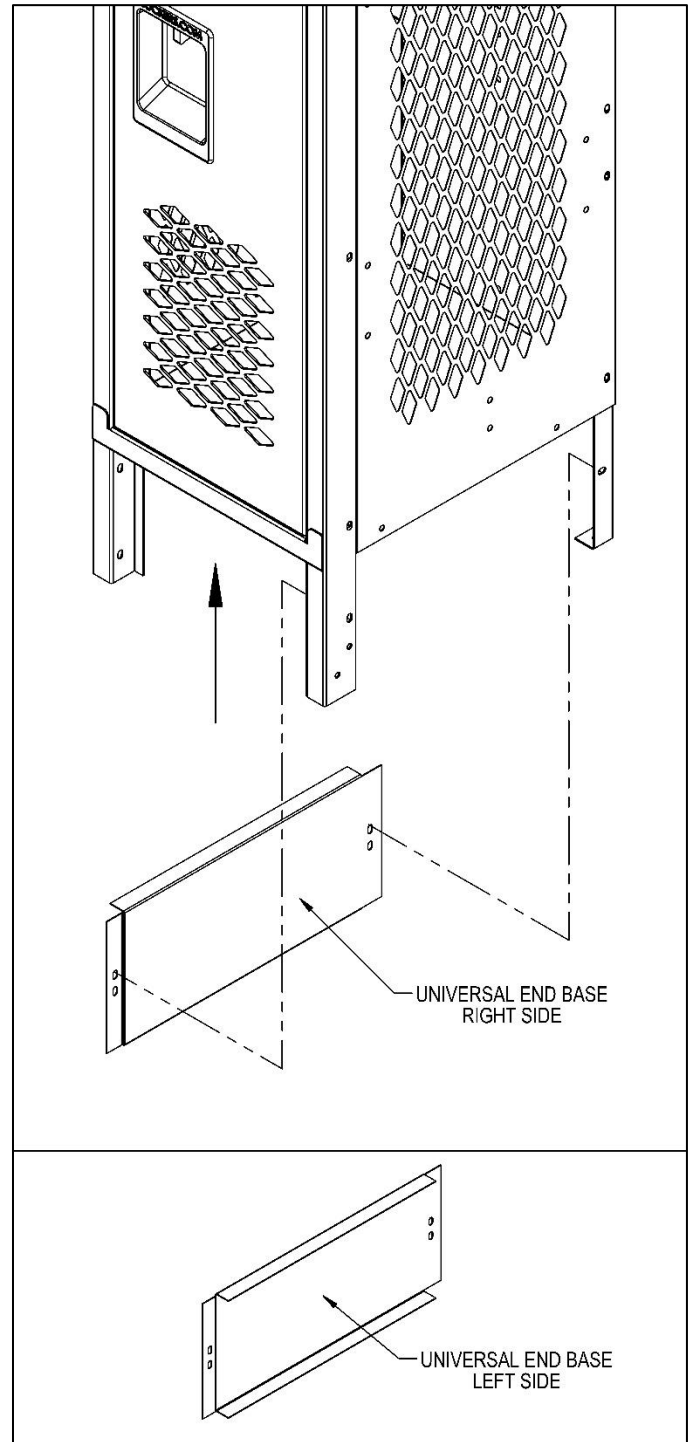

SALSBURY INDUSTRIES

18300 Central Avenue, Carson, CA 90746-4008
Phone: 1-800-562-5377 Int'l Phone: 323-846-6700
Fax: 1-800-562-5399 Int'l Fax: 323-846-6800
www.lockers.com engineering@lockers.com